

## 母预绝缘接头 INSULATED FEMALE DISCONNECTS

导线截面: 0.5 ~ 1.5mm<sup>2</sup>(美国线规22-16) 最大电流 · I<sub>max</sub>=10A 材质: 黄铜



型号 ITEM NO	NAMETAB 接插规格 mm	材料 厚度 Thickness of material mm	尺寸 DIMENSION				
			B mm	dφ mm	Dφ mm	L mm	H mm
FDD 1.25-110(5)	0.5×2.8	0.3	3.8	1.7	3.8	19.0	10.0
FDD 1.25-110(8)	0.8×2.8	0.3	3.8	1.7	3.8	19.0	
FDD 1.25-187(5)	0.5×4.75	0.35	5.6	1.7	3.8	19.0	
FDD 1.25-187(8)	0.8×4.75	0.35	5.6	1.7	3.8	19.0	
FDD 1.25-205	0.5×5.2	0.35	6.5	1.7	3.8	20.0	
FDD 1.25-250	0.8×6.35	0.4	7.4	1.7	3.8	21.0	

导线截面: 1.5 ~ 2.5mm<sup>2</sup>(美国线规16-14) 最大电流 · I<sub>max</sub>=15A



型号 ITEM NO	NAMETAB 接插规格 mm	材料 厚度 Thickness of material mm	尺寸 DIMENSION				
			B mm	dφ mm	Dφ mm	L mm	H mm
FDD 2-110(5)	0.5×2.8	0.3	3.8	2.3	4.3	19.0	10.0
FDD 2-110(8)	0.8×2.8	0.3	3.8	2.3	4.3	19.0	
FDD 2-187(5)	0.5×4.75	0.35	5.6	2.3	4.3	19.0	
FDD 2-187(8)	0.8×4.75	0.35	5.6	2.3	4.3	19.0	
FDD 2-205	0.5×5.2	0.35	6.5	2.3	4.3	20.0	
FDD 2-250	0.8×6.35	0.4	7.4	2.3	4.3	21.0	
FDD 2-312	0.8×8.0	0.4	9.0	2.3	4.3	23.0	

导线截面: 4 ~ 6mm<sup>2</sup>(美国线规12-10) 最大电流 · I<sub>max</sub>=24A

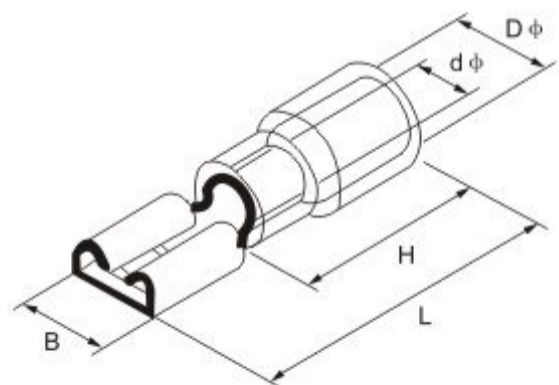

型号 ITEM NO	NAMETAB 接插规格 mm	材料 厚度 Thickness of material mm	尺寸 DIMENSION				
			B mm	dφ mm	Dφ mm	L mm	H mm
FDD 5.5-187	0.5×4.75	0.4	5.6	3.4	5.7	23.0	14.0
FDD 5.5-250	0.8×6.35	0.4	7.4	3.4	5.7	25.0	
FDD 5.5-312	0.8×8.0	0.5	9.0	3.4	5.7	27	
FDD 5.5-375	1.2×9.4	0.5	10.9	3.4	5.7	29.6	

## 公预绝缘接头 INSULATED MALE DISCONNECTS



导线截面: 0.5 ~ 1.5mm<sup>2</sup>(美国线规22-16) 最大电流 · I<sub>max</sub>=10A 材质: 黄铜

型号 ITEM NO	NAMETAB 接插规格	材料 厚度 Thickness of material	尺寸 DIMENSION				
			B	dφ	Dφ	L	H
			mm	mm	mm	mm	mm
MDD 1.25-110(5)	0.5×2.8	0.5	2.8	1.70	4.3	17.7	10.0
MDD 1.25-110(8)	0.8×2.8	0.8	2.8	1.70	4.3	17.7	
MDD 1.25-187(5)	0.5×4.75	0.5	4.75	1.70	4.3	18.5	
MDD 1.25-187(8)	0.8×4.75	0.8	4.75	1.70	4.3	18.5	
MDD 1.25-250	0.8×6.3	0.4	6.3	1.70	4.3	21.0	

导线截面: 1.5 ~ 2.5mm<sup>2</sup>(美国线规16-14) 最大电流 · I<sub>max</sub>=15A

型号 ITEM NO	NAMETAB 接插规格	材料 厚度 Thickness of material	尺寸 DIMENSION				
			B	dφ	Dφ	L	H
			mm	mm	mm	mm	mm
MDD 2-110(5)	0.5×2.8	0.5	2.8	2.3	4.3	17.7	10.0
MDD 2-110(8)	0.8×2.8	0.8	2.8	2.3	4.3	17.7	
MDD 2-187(5)	0.5×4.75	0.5	4.75	2.3	4.3	18.5	
MDD 2-187(8)	0.8×4.75	0.8	4.75	2.3	4.3	18.5	
MDD 2-250	0.8×6.35	0.4	6.35	2.3	4.3	21.0	

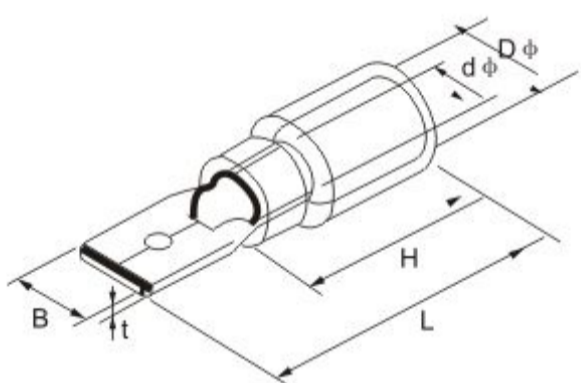

导线截面: 4 ~ 6mm<sup>2</sup>(美国线规12-10) 最大电流 · I<sub>max</sub>=24A

型号 ITEM NO	NAMETAB 接插规格	材料 厚度 Thickness of material	尺寸 DIMENSION				
			B	dφ	Dφ	L	H
			mm	mm	mm	mm	mm
MDD 5.5-187	0.5×4.75	0.5	4.75	3.4	5.7	23.0	14.0
MDD 5.5-250	0.8×6.3	0.4	6.3	3.4	5.7	25.0	