

TKS 凯赛电气

——冷压接线端头及接头专业制造商



乐清凯赛电气有限公司
YUEQING KAISAI ELECTRIC CO., LTD.

产品概览

PRODUCT OVERVIEW



产品概览

PRODUCT OVERVIEW



叉形预绝缘端头(TU-JTK型) INSULATED SPADE TERMINALS

注: 红绿黄兰白黑任意选购。



导线截面: 0.5~1.5mm²(美国线规22~16) 最大电流·I_{max}=19A

紫铜0.7mm

型号 ITEMNO	尺寸DIMENSION							颜色 COLOR
	美制螺栓号	螺栓口直径 d2	B mm	L mm	F mm	H mm	Dφ mm	
SV 1.25-3	#4	3.2mm	5.7	21.2	6.5	10.0	4.3	红 red
SVS 1.25-3.5	#6	3.7mm	5.7	21.2	6.5			
SVL 1.25-3.5	#6	3.7mm	6.4	21.2	6.5			
SVS 1.25-4	#8	4.3mm	6.4	21.2	6.5			
SVM 1.25-4	#8	4.3mm	7.2	21.2	6.5			
SVL 1.25-4	#8	4.3mm	8.1	21.2	6.5			
SVS 1.25-5	#10	5.3mm	8.1	21.2	6.5			
SVL 1.25-5	#10	5.3mm	9.5	21.2	6.5			
SVS 1.25-6	1/4	6.5mm	9.5	21.2	6.5			
SVL 1.25-6	1/4	6.5mm	12.0	27.2	11.0			
SV 1.25-8	5/16	8.5mm	14.0	29.0	12.5			

导线截面: 1.5~2.5mm²(美国线规16~14) 最大电流·I_{max}=27A

紫铜0.8mm

型号 ITEMNO	尺寸DIMENSION							颜色 COLOR
	美制螺栓号	螺栓口直径 d2	B mm	L mm	F mm	H mm	Dφ mm	
SV 2-3	#4	3.2mm	5.7	21.2	6.5	10.0	4.9	兰 blue
SVS 2-3.5	#6	3.7mm	5.7	21.2	6.5			
SVL 2-3.5	#6	3.7mm	6.4	21.2	6.5			
SVS 2-4	#8	4.3mm	6.4	21.2	6.5			
SVM 2-4	#8	4.3mm	7.2	21.2	6.5			
SVL 2-4	#8	4.3mm	8.1	21.2	6.5			
SVS 2-5	#10	5.3mm	8.1	21.2	6.5			
SVL 2-5	#10	5.3mm	9.5	21.2	6.5			
SVS 2-6	1/4	6.5mm	9.5	21.2	6.5			
SVL 2-6	1/4	6.5mm	12.0	27.2	11.0			
SV 2-8	5/16	8.5mm	14.0	29.0	12.5			

导线截面: 2.5~4mm²(美国线规14~12) 最大电流·I_{max}=37A

紫铜1.0mm

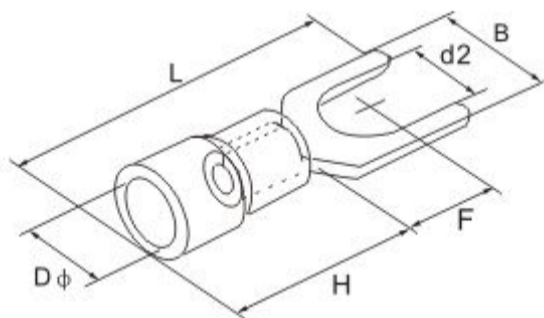

型号 ITEMNO	尺寸DIMENSION							颜色 COLOR
	美制螺栓号	螺栓口直径 d2	B mm	L mm	F mm	H mm	Dφ mm	
SV3.5-3	#4	3.2mm	5.7	24.8	7.0	12.5	6.2	黑 black
SV 3.5-4	#8	4.3mm	8.0	24.8	7.0			
SV 3.5-5	#10	5.3mm	8.0	24.8	7.0			
SV 3.5-6	1/4	6.5mm	12.0	28.0	12.1			

导线截面: 4~6mm²(美国线规12~10) 最大电流·I_{max}=48A

紫铜1.0mm

型号 ITEMNO	尺寸DIMENSION							颜色 COLOR
	美制螺栓号	螺栓口直径 d2	B mm	L mm	F mm	H mm	Dφ mm	
SV 5.5-3.5	#6	3.7mm	8.3	25.2	7.5	12.5	6.7	黄 yellow
SVS 5.5-4	#8	4.3mm	8.3	25.2	7.5			
SVL 5.5-4	#8	4.3mm	9.0	25.2	7.5			
SV 5.5-5	#10	5.3mm	9.0	25.2	7.5			
SVS 5.5-6	1/4	6.5mm	9.0	25.2	7.5			
SVL 5.5-6	1/4	6.5mm	12.0	31.2	12.0			
SV 5.5-8	1/4	8.4mm	14.0	30.0	11.5			