

TKS 凯赛电气

——冷压接线端头及接头专业制造商



乐清凯赛电气有限公司
YUEQING KAISAI ELECTRIC CO., LTD.

> 叉形裸端头(TU型) NON-INSULATED SPADE TERMINALS



导线截面: 0.5~1.5mm²(美国线规22~16) 最大电流·I_{max}=19A 紫铜0.7mm

型号 ITEMNO	尺寸DIMENSION							
	美制螺栓号	螺栓口直径 d2	B mm	L mm	F mm	E mm	Dφ mm	dφ mm
SNB 1.25-3	#4	3.2mm	5.7	16.0	6.5	4.8	3.4	1.7
SNBS 1.25-3.5	#6	3.7mm	5.7	16.0	6.5			
SNBL 1.25-3.5	#6	3.7mm	6.4	16.0	6.5			
SNBS 1.25-4	#8	4.3mm	6.4	16.0	6.5			
SNBM 1.25-4	#8	4.3mm	7.2	16.0	6.5			
SNBL 1.25-4	#8	4.3mm	8.1	16.0	6.5			
SNBS 1.25-5	#10	5.3mm	8.1	16.0	6.5			
SNBL 1.25-5	#10	5.3mm	9.5	16.0	6.5			
SNBS 1.25-6	1/4	6.5mm	9.5	16.0	6.5			
SNBL 1.25-6	1/4	6.5mm	12.0	22.0	11.0			
SNB 1.25-8	5/16	8.4mm	14.0	23.5	12.5			

导线截面: 1.5~2.5mm²(美国线规16~14) 最大电流·I_{max}=27A 紫铜0.8mm

型号 ITEMNO	尺寸DIMENSION							
	美制螺栓号	螺栓口直径 d2	B mm	L mm	F mm	E mm	Dφ mm	dφ mm
SNB 2-3	#4	3.2mm	5.7	16.0	6.5	4.8	4.1	2.3
SNBS 2-3.5	#6	3.7mm	5.7	16.0	6.5			
SNBL 2-3.5	#6	3.7mm	6.4	16.0	6.5			
SNBS 2-4	#8	4.3mm	6.4	16.0	6.5			
SNBM 2-4	#8	4.3mm	7.2	16.0	6.5			
SNBL 2-4	#8	4.3mm	8.1	16.0	6.5			
SNBS 2-5	#10	5.3mm	8.1	16.0	6.5			
SNBL 2-5	#10	5.3mm	9.5	16.0	6.5			
SNBS 2-6	1/4	6.5mm	9.5	16.0	6.5			
SNBL 2-6	1/4	6.5mm	12.0	22.0	11.0			
SNB 2-8	5/16	8.4mm	14.0	23.5	12.5			

导线截面: 2.5~4mm²(美国线规14~12) 最大电流·I_{max}=37A 紫铜1.0mm

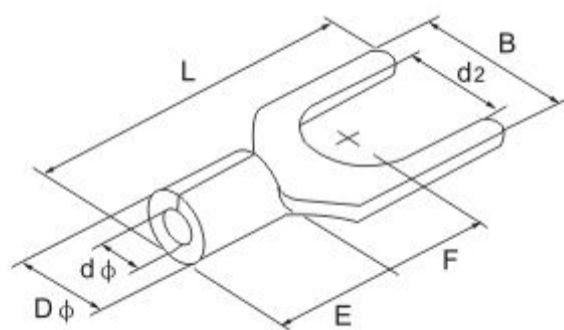

型号 ITEMNO	尺寸DIMENSION							
	美制螺栓号	螺栓口直径 d2	B mm	L mm	F mm	E mm	Dφ mm	dφ mm
SNB 3.5-3	#4	3.2mm	5.7	18.3	7.0	6.0	5.0	3.0
SNB 3.5-4	#8	4.3mm	8.0	18.3	7.0			
SNB 3.5-5	#10	5.3mm	8.0	18.3	7.0			
SNB 3.5-6	1/4	6.5mm	12.0	21.5	12.1			

导线截面: 4~6mm²(美国线规12~10) 最大电流·I_{max}=48A 紫铜1.0mm

型号 ITEMNO	尺寸DIMENSION							
	美制螺栓号	螺栓口直径 d2	B mm	L mm	F mm	E mm	Dφ mm	dφ mm
SNB 5.5--3.5	#6	3.7mm	8.3	19.5	7.5	6.8	5.6	3.4
SNBS 5.5-4	#8	4.3mm	8.3	19.5	7.5			
SNBL 5.5-4	#8	4.3mm	9.0	19.5	7.5			
SNB 5.5-5	#10	5.3mm	9.0	19.5	7.5			
SNBS 5.5-6	1/4	6.5mm	9.0	19.5	7.5			
SNBL 5.5-6	1/4	6.5mm	12.0	25.5	12.0			
SNB 5.5-8	5/16	8.4mm	14.0	24.5	11.5			

> 叉形裸端头(TU型) NON-INSULATED SPADE TERMINALS



型号 ITEMNO	电线范围 A.G.W	螺栓尺寸	尺寸DIMENSION						最大 电流
		d2	B	F	L	E	D	d1	
SNB 8-4	8AWG 6-10 ²	4.3	8.0	7.2	23.0	8.5	7.2	4.5	62A
SNB 8-5	8AWG 6-10 ²	5.3	10.8	7.2	23.0	8.5	7.2	4.5	62A
SNB 8-6	8AWG 6-10 ²	6.5	10.8	7.2	23.0	8.5	7.2	4.5	62A
SNB 8-8	8AWG 6-10 ²	8.4	14.5	13.0	27.8	8.5	7.2	4.5	62A
SNB 14-5	6AWG 10-16 ²	5.3	12.0	10.7	25.5	10.5	9.0	5.8	88A
SNB 14-6	6AWG 10-16 ²	6.5	12.0	10.7	25.5	10.5	9.0	5.8	88A
SNB 14-8	6AWG 10-16 ²	8.4	13.8	10.7	28.5	10.5	9.0	5.8	88A
SNB 22-6	4AWG 16-25 ²	6.5	14.0	9.0	34.5	12.0	11.5	7.7	115A
SNB 22-8	4AWG 16-25 ²	8.4	14.0	9.0	34.5	12.0	11.5	7.7	115A

> 预绝缘端头 PRE-INSULATION TERMINALS

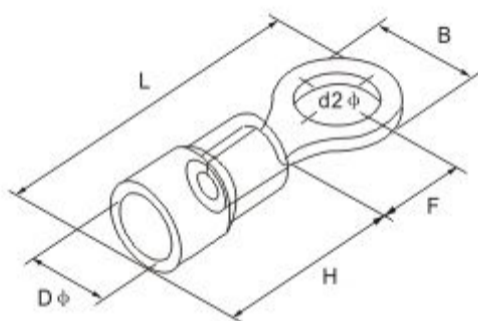

导线截面: 6~10mm²(美国线规8) 最大电流·Imax=62A

型号 ITEMNO	尺寸DIMENSION						颜色
	螺栓口 直径	B	L	F	E	Dφ	
	D2φ	mm	mm	mm	mm	mm	
SV8-5	5.3	10.8	31	9	16	9.5	红色
SV8-6	6.5	10.8	31	9			
SV8-8	8.5	14.8	38	13.5			
RV8-4	4.3	8.8	31	9.3			
RV8-5S	5.5	8.8	31	9.3			
RV8-5M	5.5	12.0	32.3	9.3			
RV8-6S	6.5	12.0	32.3	9.3			
RV8-6L	6.5	15.0	38.3	13.8			
RV8-8	8.5	15.0	38.3	13.8			
RV8-10	10.5	15.0	38.3	13.8			
RV8-12	12.5	22.0	48	17.0			

> 绝缘软套管 TERMINAL INSULATION

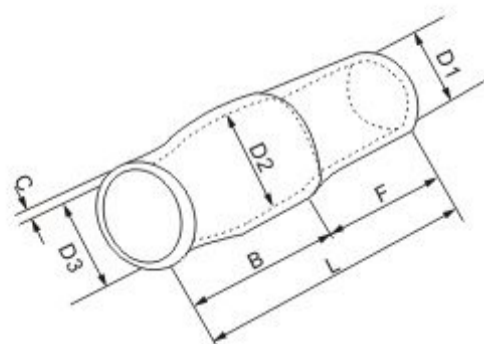

型号 ITEM NO	尺寸DIMENSION						
	D1	D2	D3	L	F	B	C
	mm	mm	mm	mm	mm	mm	mm
V-1.25	2.8	3.3	3.1	13	6	7	0.6
V-2	3.3	4.5	3.7	14	7	7	0.7
V-3.5	4.2	5.7	4.1	17	9	8	0.8
V-5.5	4.8	5.7	5.2	17	9	8	0.8
V-8	6.2	7.2	6.2	19	10	9	1.0
V-14	7.5	10	8	25	14	11	1.1
V-22	10.5	12	9.5	30	15	15	1.2
V-38	12.5	14	11.8	34	17.5	16.5	1.5
V-60	15	16.8	13.5	39	20	19	1.5
V-70	16	17.5	14.5	43	22	20	1.5
V-80	17	19	16	47	25	22	1.6
V-100	19	22	18	54	30	24	1.7
V-125	21	24	20	57	32	25	1.8
V-150	23	24.5	22	65	35	30	2.0
V-200	27	32	24	65	35	30	2.0
V-240	29	38	26.5	77	35	39	2.5
V-325	29	38	29	77	37	40	2.5
V-400	42	45	36	85	46	41	2.5
V-500	46	48	40	88	41	42	2.5
V-630	52	54	44	92	50	47	2.5