

HYBRID INVERTER ES Series



Features:

- ◆ Li-ion /Lead-acid battery
- ◆ Operation:On-grid(5kW),Charging and discharging(3kW),Backup(3kW)
- ◆ Zero export to grid
- ◆ U-disk for software updating
- ◆ Without LCD,no risk of dust or water
- ◆ Seperate APP setting/monitoring
- ◆ Wi-Fi/GPRS
- ◆ Lantrun Pad local monitoring

Efficiency Chart

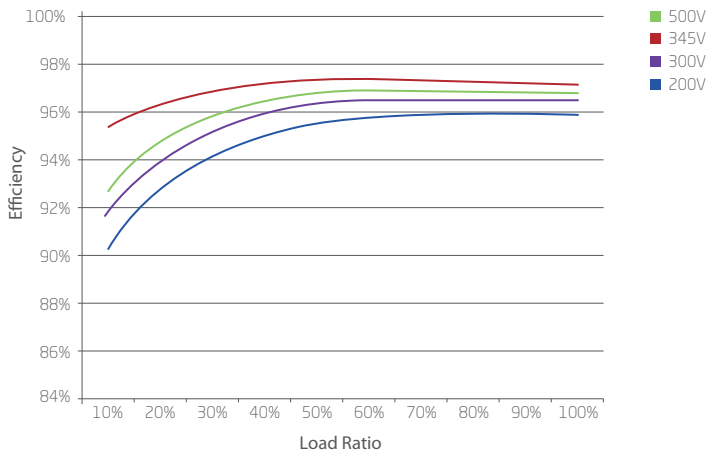

www.lantrun.com

Electrical Diagram

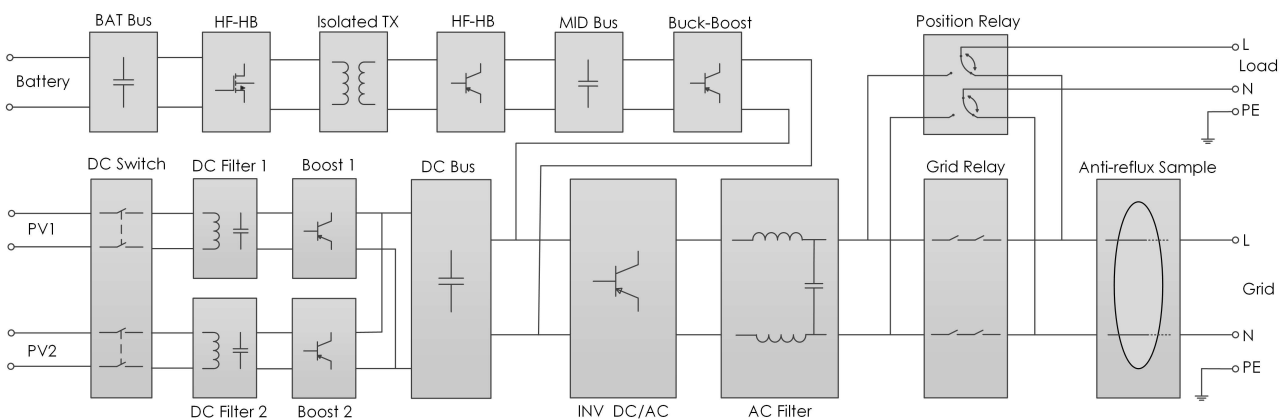

SPECIFICATION

Specifications	Model	Aegis 3600ES	Aegis 4600ES	Aegis 5000ES
Input Data (DC)				
Max. DC power		3800W	5000W	5400W
Max. DC voltage			600V	
Start voltage			100V	
DC nominal voltage			360V	
PV voltage range			100V-600V	
MPP voltage range			120V-550V	
Max. input current per string of tracker A/tracker B			11A/11A	
Number of independent MPP inputs			2	
Output Data (AC)				
Nominal AC output power		3600W	4600W	5000W
Max. AC apparent power		3600VA	4600VA	5000VA
Max. output current		16.4 A	21.0A	22.8A
AC nominal voltage; range			220V/230V/240V; 180V-280V	
AC grid frequency; range			50,60Hz;±5 Hz	
Power factor at rate power			1	
Power factor			0.8leading...0.8lagging	
THDi			<3%	
AC connection			Single phase	
Battery				
Battery type			Lead-acid or Li-ion	
Norminal voltage			48V	
Battery capacity			≥100Ah(depending requirement)	
Energy			4.88kWh	
Max. discharging /charging power			2500W / 2500W	
Charging curve			3-stage adaptive with maintenance	
Operating voltage range			46V-57V	
Max. charging/discharging current			50A / 50A	
Backup Output				
Output rate power			2300VA	
Peak power			3450VA,10s	
Output voltage			230V±2%, 50Hz (60Hz Optional)±0.2%, THDv<3%(linear load)	
Efficiency				
		97.00%	97.10%	97.10%
Max. efficiency		96.50%	96.50%	96.50%
Euro - eta		99.50%	99.50%	99.50%
MPPT efficiency				
Protection Devices				
DC reverse polarity protection			Yes	
DC switch rating for each MPPT			Yes	
Output over current protection			Yes	
Output overvoltage protection-varistor			Yes	
Ground fault monitoring			Yes	
Grid monitoring			Yes	
Integrated all - pole sensitive leakage current monitoring unit			Yes	
General Data				
Dimensions (W / H / D)			495/420/165mm	
Weight		24kg	24kg	24kg
Operating temperature range		-25...+60°C (-13...+ 140°F) With derating above 45°C (113°F)		
Noise emission (typical)			≤ 25 dB(A)	
Altitude			Up to 2000m (6560ft) Without power derating	
Relative humidity			95%	
Consumption: operating (standby) / night			<5W / < 0.5 W	
Topology			Transformerless	
Cooling concept			Natural	
Environmental Protection Rating			IP65	
Features				
DC connection			H4/MC4	
AC connection			Screw terminal	
Display			LED	
Interfaces: Wi-Fi/USB/GPRS/RS485			Yes/Yes/Opt/Opt	
Warranty: 5 years / 10 years/15 years			Yes /Opt/Opt	
Certificates and approvals			CE,IEC 62109-1&2, VDE 0126-1-1,G83/2, AS4777&AS/NZS 3100	